

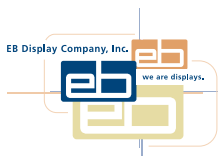

# STOR-RITE

2015 CATALOG



**SALES OFFICE:** PH: 1.800.321.9869 • FAX: 330.833.9844  
**STOCK ORDERS:** PH: 1.800.832.6967 • FAX: 330.830.3048

[www.ebdisplay.com](http://www.ebdisplay.com)

DIVISIONS OF EB:     
© 2011 EB Display Company, Inc.



## The Sales Pacer

Classic medium duty gondola style merchandiser. Designed for both end-cap or medium duty in-line one side fixturing.

<b>FEATURES</b>	Rigid Construction Easy Assembly No Tools Required	Durable Powdered Finish 1" Vertical Shelf Adjustment
<b>HEIGHT</b>	54" (up to 72" with extenders)	
<b>WIDTH</b>	24", 36" and 48"	
<b>DEPTH</b>	Merchandisable Space 14" to peg panel. 16 - 3/4" overall	
<b>COLORS</b>	Beige and walnut brown with white peg panel	
<b>LOAD CAPACITY</b>	300 lb. total maximum 120 lb. maximum on base shelf 90 lb. maximum per upper shelf	

**\*\* All shelf pricing reflects individual shelf price.**

### Sales Pacer - 24"

PART NUMBER	DESCRIPTION	SHIP WT. #	Price
SP2454	24 x 54 Sales Pacer	32	65.57
SPUS2410	24 x 10 Upper Shelf	6	15.80
SPUS2412	24 x 12 Upper Shelf	7	17.31
SPEX2406	24 x 6 Extender Kit	4.5	17.61
SPEX2418	24 x 18 Extender Kit	9	24.10

**\*\* Pricing for larger quantities available upon request**

### Sales Pacer - 36"

Part Number	Description	SHIP WT. #	Price
SP3654	36 x 54 Sales Pacer	36	86.63
SPUS3610	36 x 10 Upper Shelf	7	18.05
SPUS3612	36 x 12 Upper Shelf	9	20.56
SPEX3606	36 x 6 Extender Kit	5	19.63
SPEX3618	36 x 18 Extender Kit	10	26.56

**\*\* Pricing for larger quantities available upon request**

### Sales Pacer - 48"

Part Number	Description	SHIP WT. #	Price
SP4854	48 x 54 Sales Pacer	47	99.79
SPUS4810	48 x 10 Upper Shelf	9	20.14
SPUS4812	48 x 12 Upper Shelf	11	23.06
SPEX4806	48 x 6 Extender Kit	6	21.44
SPEX4818	48 x 18 Extender Kit	12	31.35

**\*\* Pricing for larger quantities available upon request**

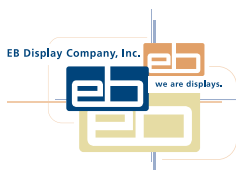

**SALES OFFICE:** PH: 1.800.321.9869 • FAX: 330.833.9844  
**STOCK ORDERS:** PH: 1.800.832.6967 • FAX: 330.830.3048

[www.ebdisplay.com](http://www.ebdisplay.com)

DIVISIONS OF EB:     
 © 2010 EB Display Company, Inc.



## Double-Sided Sales Pacer

With all the same features of the standard Sales Pacer, this merchandiser is designed to stand alone or to be used as medium duty in-line fixturing.

- HEIGHT:** 54"
- WIDTH:** 24", 36" and 48"
- DEPTH:** 14" to peg panel on both sides, 31-3/4" overall
- COLORS:** beige and walnut brown with white peg panel
- Load Capacity:** 450 lb. total maximum  
120 lb. maximum on each base shelf  
90 lb. maximum per upper shelf

### Double-Sided Sales Pacer - 48"

Part Number	Description	SHIP WT. #	Price
SPDB2454	24 x 54 Dbisided S/P	45	97.31
SPDB3654	36 x 54 Dbisided S/P	62	129.38
SPDB4854	48 x 54 Dbisided S/P	76	144.12

\*\* Pricing for larger quantities available upon request



**SALES OFFICE:** PH: 1.800.321.9869 • FAX: 330.833.9844  
**STOCK ORDERS:** PH: 1.800.832.6967 • FAX: 330.830.3048  
[www.ebdisplay.com](http://www.ebdisplay.com)



## The Huckster

The Huckster is a heavy duty gondola style merchandiser with a large load capacity. This unit is designed for use as both a free standing display or as in-line fixturing where a heavy product weight capability is required. Huckster upper shelves are adjustable in 1" increments and mount both flat and angled downward for gravity feed.

<b>HEIGHT</b>	54" , 66" (up to 84" with extender)
<b>WIDTH</b>	36" and 48"
<b>DEPTH</b>	16" , 18" , 22" (to peg panel)
<b>OVERALL DEPTH</b>	19-1/2" , 21-1/2" , 25-1/2"
<b>COLORS</b>	beige and walnut brown with white peg panel
<b>LOAD CAPACITY</b>	1,200 lb. maximum 300 lb. maximum on base shelf 140 lb. maximum per shelf

**\*\* All shelf pricing reflects individual shelf price.**

### 36" Huckster

Part Number	Description	SHIP WT. #	Price
HU366616	36 x 66 x 16 Huckster	58	120.27
HU365416	36 x 54 x 16 Huckster	55	115.67
HU366618	36 x 66 x 18 Huckster	64	123.87
HU365418	36 x 54 x 18 Huckster	62	119.18
HUUS3612	36 x 12 Upper Shelf	8	22.51
HUUS3614	36 x 14 Upper Shelf	9	22.97
HUUS3616	36 x 16 Upper Shelf	10	24.97

**\*\* Pricing for larger quantities available upon request**

### 48" Huckster

Part Number	Description	SHIP WT. #	Price
HU485416	48 x 54 x 16 Huckster	64	128.81
HU485418	48 x 54 x 18 Huckster	69	133.29
HU485422	48 x 54 x 22 Huckster	79	142.37
HU486616	48 x 66 x 16 Huckster	71	137.99
HU486618	48 x 66 x 18 Huckster	73	144.39
HU486622	48 x 66 x 22 Huckster	81	153.14
HUUS4810	48 x 10 Upper Shelf	11	24.32
HUUS4812	48 x 12 Upper Shelf	12	27.29
HUUS4814	48 x 14 Upper Shelf	13	28.88
HUUS4816	48 x 16 Upper Shelf	14	32.47
HUUS4818	48 x 18 Upper Shelf	17	36.30

**\*\* Pricing for larger quantities available upon request**



**SALES OFFICE:** PH: 1.800.321.9869 • FAX: 330.833.9844  
**STOCK ORDERS:** PH: 1.800.832.6967 • FAX: 330.830.3048  
[www.ebdisplay.com](http://www.ebdisplay.com)

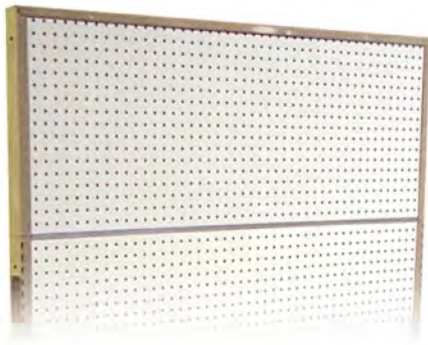

## The Huckster Extender Kit

Designed to increase the height of 66" single sided Huckster merchandiser to 84" height. Typical of end cap displays used with aisle fixtures or as against the wall in-line fixtures. Extender kits are not available for 54" or 66" double sided Huckster merchandisers.

<b>HEIGHT</b>	18"
<b>WIDTH</b>	36" and 48"
<b>COLORS</b>	beige and walnut brown with white peg panel
<b>LOAD CAPACITY</b>	80 lb. maximum on shelf or peg panel

### Huckster Extender Kit

Part Number	Description	SHIP WT. #	Price
HUEX3618	36" x 18" Huckster Extender Kit	14	33.26
HUEX4818	48" x 18" Huckster Extender Kit	15	38.04

\*\* Pricing for larger quantities available upon request



## The Double Sided Huckster

With all the same features as the standard Huckster, this merchandiser is designed to stand alone or to be used as heavy duty in-line fixturing.

<b>HEIGHT</b>	54"
<b>WIDTH</b>	48"
<b>DEPTH</b>	16" , 18" , 22" to peg panel on both sides
<b>OVERALL DEPTH</b>	36-3/8" , 40-3/8" , 48-3/8"
<b>COLORS</b>	beige and walnut brown with white peg panel
<b>LOAD CAPACITY</b>	1,500 lb. maximum 300 lb. maximum on each base shelf 140 lb. maximum per shelf

### Double Sided Huckster

Part Number	Description	SHIP WT. #	Price
HUDB365416	36 x 54 x 16 Dblsided	83	184.24
HUDB365418	36 x 54 x 18 Dblsided	94	187.67
HUDB485416	48 x 54 x 16 Dblsided	98	192.78
HUDB485418	48 x 54 x 18 Dblsided	109	196.29
HUDB485422	48 x 54 x 22 Dblsided	114	209.46

\*\* Pricing for larger quantities available upon request



**SALES OFFICE:** PH: 1.800.321.9869 • FAX: 330.833.9844  
**STOCK ORDERS:** PH: 1.800.832.6967 • FAX: 330.830.3048  
[www.ebdisplay.com](http://www.ebdisplay.com)

## Peghooks

NOTE: Many other styles of peghooks are available on a special order basis.

No minimum qty.

### 1/8" Light Duty Ballend Peghooks

Part Number	Size	Price
12401802	1/8" x 2"	0.12
12401804	1/8" x 4"	0.16
12401806	1/8" x 6"	0.18
12401808	1/8" x 8"	0.21
12401810	1/8" x 10"	0.28

### 1/4" Heavy Duty Ballend Peghooks

Part Number	Size	Price
12401404	1/4" x 4"	0.32
12401406	1/4" x 6"	0.35
12401408	1/4" x 8"	0.36
12401410	1/4" x 10"	0.40
12401412	1/4" x 12"	0.47

### 3/16" Medium Duty Ballend Peghooks

Part Number	Size	Price
12403604	3/16" x 4"	0.21
12403606	3/16" x 6"	0.23
12403608	3/16" x 8"	0.28
12403610	3/16" x 10"	0.30
12403612	3/16" x 12"	0.35

### 1/8" Diameter Hairpin Hooks

Part Number	Size	Price
12402529	4"	0.23
12402179	6"	0.29
12401772	8"	0.30
12402571	10"	0.33
12402478	12"	N/A

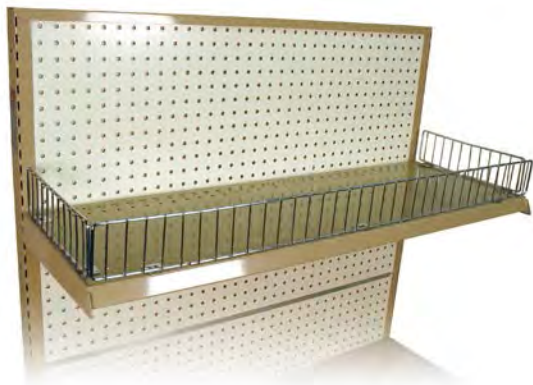

## Snap Lock Binning

3" high welded binning used to create divided sections on shelves. Binning snaps into place through the diamond perforations on the base shelf and upper shelves of Sales Pacer and Huckster Displays.

NOTE: Special sizes may be available as special order items.

**\*\*Binning pieces are finished with chrome plated and can be powder coated.**

### Snap Lock Binning - Chrome

Part Number	Description	SHIP WT. #	Price
BD311	11" Divider (For 12" U/S)	4 oz.	2.42
BD313	13" Divider (For 14" U/S)	5 oz.	2.59
BD315	15" Divider (For 16" U/S)	5 oz.	3.03
BD317	17" Divider (For 18" U/S)	5 oz.	3.26
BF324	24" Front	12 oz.	3.79
BF336	36" Front	14 oz.	5.92
BF348	48" Front	16 oz.	7.80



SALES OFFICE: PH: 1.800.321.9869 • FAX: 330.833.9844

STOCK ORDERS: PH: 1.800.832.6967 • FAX: 330.830.3048

[www.ebdisplay.com](http://www.ebdisplay.com)

DIVISIONS OF EB:  DISPLAY  WIREWORKS  STOR-A-RITE

© 2010 EB Display Company, Inc.



## Folding Wire Baskets

Designed to mount onto peg panel or slotwall, these baskets fold flat for shipping or storage. These are ideal for merchandising loose products or as dump bins. Available with dividers to make compartments in the basket.



<b>HEIGHT</b>	8"
<b>WIDTH</b>	24" or 36"
<b>DEPTH</b>	13"
<b>COLORS</b>	powder coated chrome (or powder coated to your color on special order basis.)
<b>LOAD CAPACITY</b>	24" - 50 lbs. 36" - 75 lbs.

Part Number	Description	SHIP WT. #	Price
2056812	24" Folding Basket	5	28.19
2056813	36" Folding Basket	6.5	31.53
2056921	Dividers	.5	3.79

\*\* Pricing for larger quantities available upon request

## Gondola Accessories

### Clear View 2-Piece Displayer

Adjustable for any length package. Capacity 20 lbs. Patented bracket engages at top and bottom for rigid support on 1/4" peg panel. Molded of clear FDA approved high impact polystyrene. 8" tall x 13-1/2" deep.



Part # 2522014      Weight: 17 Per Carton

Quantity of Cartons	Cost Per Carton / 10
1-100	77.50 / CTN

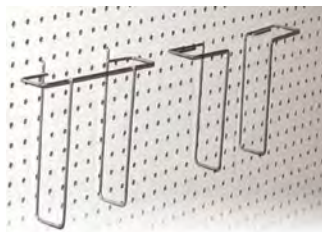

### Literature Pockets

Part Number	Width	SHIP WT. #	Price
1331954	4" : 1 Piece	2 oz.	1.99
1988904	4" : 2 Piece	2 oz.	3.10
1331958	8" : 1 Piece	6 oz.	2.39
1988908	8" : 2 Piece	6 oz.	3.24



**SALES OFFICE:** PH: 1.800.321.9869 • FAX: 330.833.9844  
**STOCK ORDERS:** PH: 1.800.832.6967 • FAX: 330.830.3048

[www.ebdisplay.com](http://www.ebdisplay.com)

DIVISIONS OF EB:     
 © 2010 EB Display Company, Inc.

## The "Wheeler Dealer"

Compact and functional, the "Wheeler Dealer" continues the Stor-Rite tradition of no tool assembly. Over its 60" height, it can hold up to 100 pounds of product. The rotors are adjustable on 3" increments.

- *Sign Holder Included*
- *Rotors Fully Adjustable on 3" Centers*
- *Radius Tip Safety Hooks*
- *Patented Sturdy Base Assembles with No Tools*
- *Ships Via UPS*

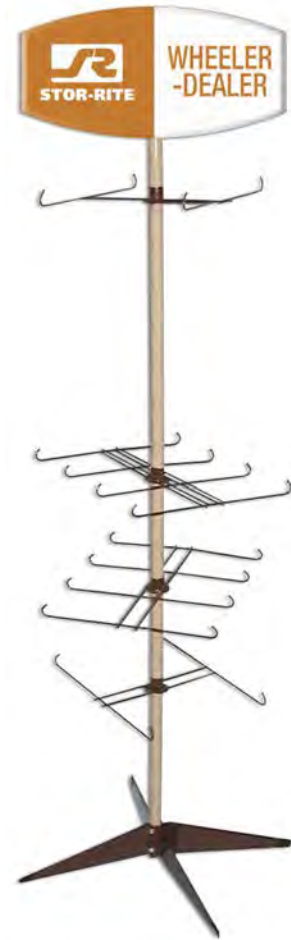

## The "Wheeler Dealer"

Part Number	Description	SHIP WT. #	Price
WD2485	Floor Display (No Rotors)	7.5	30.95
2485807	Stock 4 Arm Rotors	0.5	3.42
2485809	Stock 8 Arm Rotors	1.0	5.99

\*\* Pricing for larger quantities available upon request

**Custom rotors available in 250 minimum quantity.  
Please ask our sales desk for a quotation.**

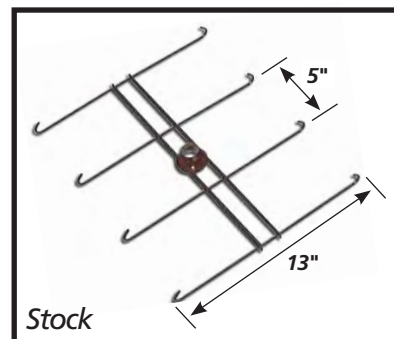
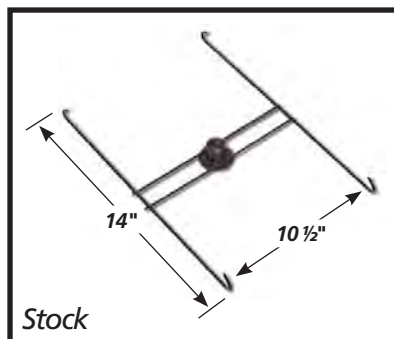

SALES OFFICE: PH: 1.800.321.9869 • FAX: 330.833.9844  
 STOCK ORDERS: PH: 1.800.832.6967 • FAX: 330.830.3048

[www.ebdisplay.com](http://www.ebdisplay.com)



## The "Drummer"

Of all the rotating peg panel displays, this is the premier unit. Patented three point suspension prevents panel bowing, and can hold up to 175 pounds. A unique assembly method locks all of the panels together so that the "Drummer" may be moved without the unit coming apart. The most attractive feature of all is the easy no tool assembly.

- *Built In Sign Holder*
- *Over 21 Square Feet of Prime Merchandising Area*
- *Panels Rotate Smoothly on Nylon Washers*
- *Three Point Suspension Keeps Panels from Bowing*
- *Panels are Edged with Walnut Brown Plastic for Better Appearance and Protection*
- *May Be Used with Clear View 2-pc. Displays and Custom Accessories*
- *Ships Via UPS*
- *Patented Walnut Brown Base Assembles Quickly with Wing Nuts and Bolts*



## The "Drummer"

Part Number	Description	SHIP WT. #	Price
DR4814	14" x 48" Panels (4)	35	95.88

\*\* Pricing for larger quantities available upon request

This versatile and space conscious display can be customized in a variety of manners including three dimensional headers and screen printing on the panels.  
(Customized peg panels are available with larger quantity orders)

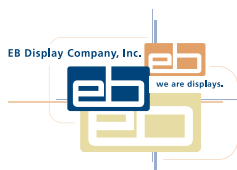

**SALES OFFICE:** PH: 1.800.321.9869 • FAX: 330.833.9844  
**STOCK ORDERS:** PH: 1.800.832.6967 • FAX: 330.830.3048

[www.ebdisplay.com](http://www.ebdisplay.com)

DIVISIONS OF EB:     
© 2010 EB Display Company, Inc.